

ATC Tech Note – Remote Amplifier Mounting

When ATC studio monitor loudspeakers must be flush/soffit mounted, the cabinet mounted amplifiers must be removed to ensure they do not overheat. Remote amp mounting solutions exist for most products to help make this as simple as possible and ensure optimal performance in these situations.

1. Speaker Cabling

All ATC active loudspeaker systems with remote amps are supplied with factory built cable assemblies so that the complete system can be tested and calibrated at the factory. Cable lengths must be specified at the point of order.

One benefit of active loudspeakers with on-board amplifiers is that speaker cables are reduced to the shortest possible length. This ensures minimal series resistance and, in turn, minimises signal loss and maintains the highest possible amplifier damping factor.

The potential exists with remote amp installs that audio quality can suffer due to inferior quality cabling and excessive cable lengths. To avoid signal degradation, **speaker cables should be kept as short as possible by mounting the amplifiers as close as possible to the loudspeaker locations.** Speaker cable runs over 10m/33' should be avoided if possible.

See table at the end of this document detailing dB loss and amp damping factor loss vs cable length.

2. SCM20ASL Pro

There is no current off-the-shelf system for remote mounting the amplifier from this product. If you have a special requirement, please contact us to discuss. info@atc.gb.net

3. SCM25/45 Amplifier Remote Mounting

Dual SCM25/45 Rack Mount Amp

Triple SCM25/45 Rack Mount Amp

A 2-channel (stereo) and 3-channel (triple/LCR) 5U 19" rack mount amplifier is available for the amp employed in the SCM25A Pro and SCM45A Pro. There is no solution for mounting a single amplifier. The chassis dimensions are identical for both versions and the products are differentiated by their rear panels and weight.

Balanced inputs are via three pin female chassis mount XLRs.

Speaker level outputs are via Neutrik SpeakON NL8 chassis connectors. Connections to the cabinet mounted

off/on/limit LED are via female five pin chassis mount XLRs.

All connectors are on the rear panel.

This product is factory build only. It can't be used to retro-fit to existing amplifiers in the field.

Full product details are available on the technical datasheet.

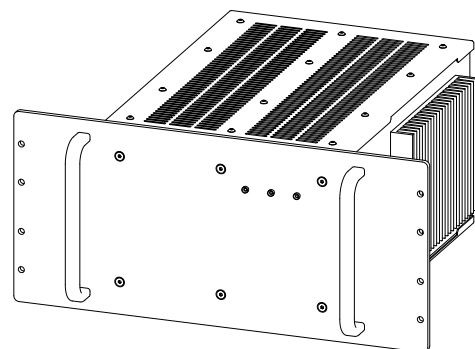

Continued over...

4. SCM50/100/110/150ASL Pro

Amp Pack Rack Kit

A single channel 6U 19" rack-mount kit is available for the amp employed in the SCM50/100/110/150. The kit consists of a 19" rack plate, amp enclosure and amp-to-enclosure wiring loom (illustrated right) that can be mounted to the standard amp pack, facilitating rack mounting. The Amp Pack Rack Kit is available as two options:

- As a kit to retro-fit to an existing amp in the field (illustrated right).
- Factory built, with amplifier as part of a new active loudspeaker system (below-left).

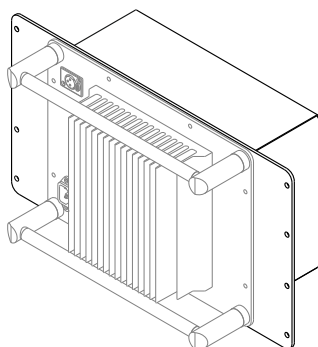
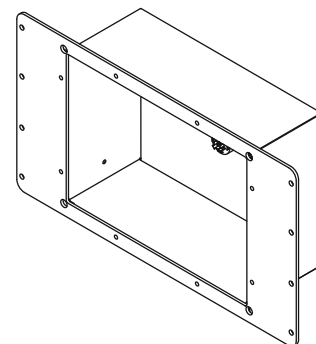

Balanced input is via three pin XLR. Mains power supply via IEC connector. Both the audio input and mains power are front panel mounted. Speaker level output is via a Neutrik SpeakON NL8 chassis connector. Connections to the cabinet mounted off/on/limit LED is via a five pin female chassis mount XLR. Both connections are mounted on the amp enclosure at the rear. Front face heatsink mounting allows in wall mounting in closest proximity to loudspeaker location, reducing loudspeaker cable lengths. Full technical product details are available on the technical datasheet.

Dual Amp Pack Rack Mount Amp

A two channel (stereo) 5U 19" rack mount amplifier is available for the amp employed in the SCM50/100/110/150. There is no solution for mounting a single amplifier in this chassis format.

Balanced inputs are via three pin XLRs. Speaker level outputs are via Neutrik SpeakON NL8 chassis connectors. Connections to the cabinet mounted On/Off/Limit LEDs are via five pin female chassis mount XLRs. All connectors are on the rear panel.

This product is factory build only. It can't be used to retro-fit to existing amplifiers in the field. Full product details are available on the technical datasheet.

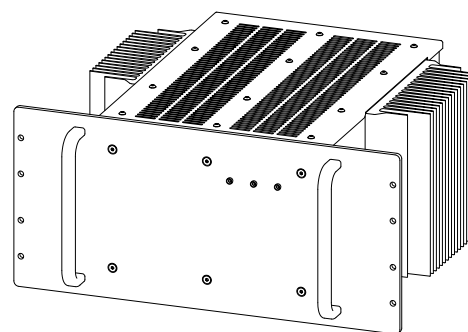

Continued over...

Sub Amp Rack Kit

A single channel 7U 19" rack-mount kit is available for the amp employed in the SCM0.1/12 and SCM0.1/15 active subwoofers. The kit consists of a 19" rack plate, amp enclosure and amp-to-enclosure wiring loom that can be mounted to the standard subwoofer amp pack, facilitating rack mounting.

The single channel rack mount kit is available as two options:

- As a kit to retro-fit to an existing amp in the field (as illustrated right).
- Ready assembled, with amplifier, as a new factory-build for ATC active subwoofers (as illustrated below).

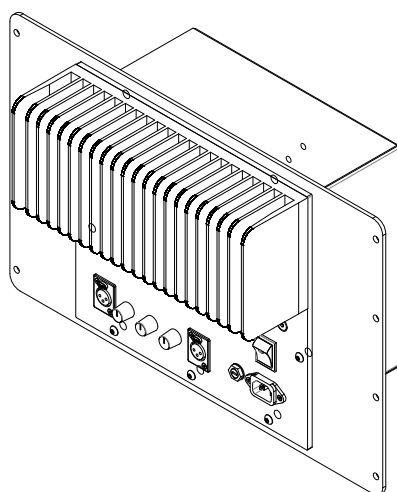
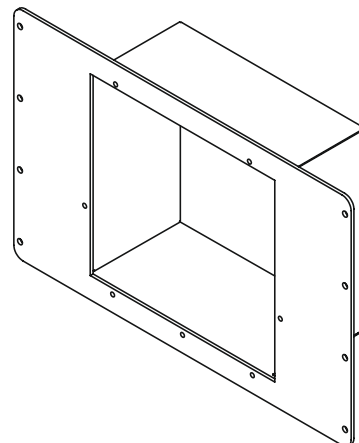

Stereo balanced inputs are via three pin XLRs (inputs sum to mono).
Mains power supply is made via IEC connector. Both the audio input and mains power are front panel mounted.
Speaker level output is via rear mounted Neutrik SpeakON NL4 chassis connector.
Front face heatsink mounting allows in-wall mounting in closest proximity to loudspeaker location, reducing loudspeaker cable lengths.

Continued over...

Table 1. dB and Damping Factor Loss Due to Cable Resistance

Cable Length (m)		2		4		6		8		10		12		14		16		18		20	
Cable Gauge	mm ²	2.5	4.0	2.5	4.0	2.5	4.0	2.5	4.0	2.5	4.0	2.5	4.0	2.5	4.0	2.5	4.0	2.5	4.0	2.5	4.0
	AWG	13	11	13	11	13	11	13	11	13	11	13	11	13	11	13	11	13	11	13	11
Cable Loop Resistance (Ω)		0.03	0.02	0.06	0.04	0.09	0.06	0.12	0.07	0.15	0.09	0.18	0.11	0.21	0.13	0.24	0.15	0.28	0.17	0.31	0.18
Amp Damping Factor inc. Cable. Ref. 8Ω		158	208	99	141	72	106	56	85	46	71	39	61	34	54	30	48	27	43	25	39
dB loss driving load of:	6 Ω	0.04	0.03	0.09	0.05	0.13	0.08	0.18	0.11	0.22	0.13	0.26	0.16	0.30	0.18	0.35	0.21	0.39	0.24	0.43	0.26
	8 Ω	0.03	0.02	0.07	0.04	0.10	0.06	0.13	0.08	0.16	0.10	0.20	0.12	0.23	0.14	0.26	0.16	0.29	0.18	0.33	0.20
	16 Ω	0.02	0.01	0.03	0.02	0.05	0.03	0.07	0.04	0.08	0.05	0.10	0.06	0.12	0.07	0.13	0.08	0.15	0.09	0.16	0.10

ATC standard cabling uses multi-stranded 2.5mm² or 4.0mm² conductors.

2.5mm² conductor typical resistance is 7.65 ohms per km. Closest AWG equivalent is 13AWG.

4.0mm² conductor typical resistance is 4.6 ohms per km. Closest AWG equivalent is 11AWG.

ATC amplifiers have a damping factor of 400 ref. 8Ω, measured at the O/P terminals.

ATC bass drivers are 8Ω parts. ATC mids are 16Ω parts. ATC HF are 6Ω parts.