



**HD 10-A MK5**





**HD 12-A MK5**

PROFESSIONAL ACTIVE SPEAKERS

---

# 1. SAFETY PRECAUTIONS AND GENERAL INFORMATION

The symbols used in this document give notice of important operating instructions and warnings which must be strictly followed.

	<b>CAUTION</b>	Important operating instructions: explains hazards that could damage a product, including data loss
	<b>WARNING</b>	Important advice concerning the use of dangerous voltages and the potential risk of electric shock, personal injury or death.
	<b>IMPORTANT NOTES</b>	Helpful and relevant information about the topic
	<b>SUPPORTS, TROLLEYS AND CARTS</b>	Information about the use of supports, trolleys and carts. Reminds to move with extreme caution and never tilt.
	<b>WASTE DISPOSAL</b>	This symbol indicates that this product should not be disposed with your household waste, according to the WEEE directive (2012/19/EU) and your national law.

## IMPORTANT NOTES

This manual contains important information about the correct and safe use of the device. Before connecting and using this product, please read this instruction manual carefully and keep it on hand for future reference. The manual is to be considered an integral part of this product and must accompany it when it changes ownership as a reference for correct installation and use as well as for the safety precautions. RCF S.p.A. will not assume any responsibility for the incorrect installation and / or use of this product.

## SAFETY PRECAUTIONS

1. All the precautions, in particular the safety ones, must be read with special attention, as they provide important information.

### 2. Power supply from mains

- The mains voltage is sufficiently high to involve a risk of electrocution; install and connect this product before plugging it in.
- Before powering up, make sure that all the connections have been made correctly and the voltage of your mains corresponds to the voltage shown on the rating plate on the unit, if not, please contact your RCF dealer.
- The metallic parts of the unit are earthed through the power cable. An apparatus with CLASS I construction shall be connected to a mains socket outlet with a protective earthing connection.
- Protect the power cable from damage; make sure it is positioned in a way that it cannot be stepped on or crushed by objects.
- To prevent the risk of electric shock, never open this product: there are no parts inside that the user needs to access.
- Be careful: in the case of a product supplied by manufacturer only with POWERCON connectors and without a power cord, jointly to POWERCON connectors type NAC3FCA (power-in) and NAC3FCB (power-out), the following power cords compliant to national standard shall be used:
  - EU: cord type H05VV-F 3G 3x2.5 mm2 - Standard IEC 60227-1
  - JP: cord type VCTF 3x2 mm2; 15Amp/120V~ - Standard JIS C3306
  - US: cord type SJT/SJTO 3x14 AWG; 15Amp/125V~ - Standard ANSI/UL 62

3. Make sure that no objects or liquids can get into this product, as this may cause a short circuit. This apparatus shall not be exposed to dripping or splashing. No objects filled with liquid, such as vases, shall be placed on this apparatus. No naked sources (such as lighted candles) should be placed on this apparatus.

4. Never attempt to carry out any operations, modifications or repairs that are not expressly described in this manual.

Contact your authorized service centre or qualified personnel should any of the following occur:

- **The product does not function (or functions in an anomalous way).**
- **The power cable has been damaged.**
- **Objects or liquids have got in the unit.**
- **The product has been subject to a heavy impact.**

5. If this product is not used for a long period, disconnect the power cable.

6. If this product begins emitting any strange odours or smoke, switch it off immediately and disconnect the power cable.

7. Do not connect this product to any equipment or accessories not foreseen.

For suspended installation, only use the dedicated anchoring points and do not try to hang this product by using elements that are unsuitable or not specific for this purpose. Also check the suitability of the support surface to which the product is anchored (wall, ceiling, structure, etc.), and the components used for attachment (screw anchors, screws, brackets not supplied by RCF etc.), which must guarantee the security of the system / installation over time, also considering, for example, the mechanical vibrations normally generated by transducers.

To prevent the risk of falling equipment, do not stack multiple units of this product unless this possibility is specified in the user manual.

**8. RCF S.p.A. strongly recommends this product is only installed by professional qualified installers (or specialised firms) who can ensure correct installation and certify it according to the regulations in force.**

**The entire audio system must comply with the current standards and regulations regarding electrical systems.**

### 9. Supports, trolleys and carts.



The equipment should be only used on supports, trolleys and carts, where necessary, that are recommended by the manufacturer. The equipment / support / trolley / cart assembly must be moved with extreme caution. Sudden stops, excessive pushing force and uneven floors may cause the assembly to overturn. Never tilt the assembly.

10. There are numerous mechanical and electrical factors to be considered when installing a professional audio system (in addition to those which are strictly acoustic, such as sound pressure, angles of coverage, frequency response, etc.).

### 11. Hearing loss.

Exposure to high sound levels can cause permanent hearing loss. The acoustic pressure level that leads to hearing loss is different from person to person and depends on the duration of exposure. To prevent potentially dangerous exposure to high levels of acoustic pressure, anyone who is exposed to these levels should use adequate protection devices. When a transducer capable of producing high sound levels is being used, it is therefore necessary to wear ear plugs or protective earphones. See the manual technical specifications to know the maximum sound pressure level.

## OPERATING PRECAUTIONS

- Place this product far from any heat sources and always ensure an adequate air circulation around it.
- Do not overload this product for a long time.
- Never force the control elements (keys, knobs, etc.).
- Do not use solvents, alcohol, benzene or other volatile substances for cleaning the external parts of this product.

## IMPORTANT NOTES

To prevent the occurrence of noise on line signal cables, use screened cables only and avoid putting them close to:

- **Equipment that produces high-intensity electromagnetic fields**
- **Power cables**
- **Loudspeaker lines**

 **WARNING! CAUTION! To prevent the risk of fire or electric shock, never expose this product to rain or humidity.**

 **WARNING! To prevent electric shock hazard, do not connect to mains power supply while grille is removed**

 **WARNING! to reduce the risk of electric shock, do not disassemble this product unless you are qualified. Refer servicing to qualified service personnel.**

## CORRECT DISPOSAL OF THIS PRODUCT



This product should be handed over to an authorized collection site for recycling waste electrical and electronic equipment (EEE). Improper handling of this type of waste could have a possible negative impact on the environment and human health due to potentially hazardous substances

that are generally associated with EEE. At the same time, your cooperation in the correct disposal of this product will contribute to the effective usage of natural resources. For more information about where you can drop off your waste equipment for recycling, please contact your local city office, waste authority or your household waste disposal service.

## CARE AND MAINTENANCE

To ensure a long-life service, this product should be used following these advices:

- If the product is intended to be set up outdoors, be sure it is under cover and protected to rain and moisture.
- If the product needs to be used in a cold environment, slowly warm up the voice coils by sending a low-level signal for about 15 minutes before sending high-power signals.
- Always use a dry cloth to clean the exterior surfaces of the speaker and always do it when the power is turned off.



**CAUTION:** to avoid damaging the exterior finishes do not use cleaning solvents or abrasives.



**WARNING! CAUTION!** For powered speakers, do cleaning only when the power is turned off.

## FCC NOTES

This equipment has been tested and found to comply with the limits for a Class B digital device, pursuant to part 15 of the FCC Rules. These limits are designed to provide reasonable protection against harmful interference in a residential installation. This equipment generates, uses and can radiate radio frequency energy and, if not installed and used in accordance with the instructions, may cause harmful interference to radio communications. However, there is no guarantee that interference will not occur in a particular installation. If this equipment does cause harmful interference to radio or television reception, which can be determined by turning the equipment off and on, the user is encouraged to try to correct the interference by one or more of the following measures:

- Reorient or relocate the receiving antenna.
- Increase the separation between the equipment and receiver.
- Connect the equipment into an outlet on a circuit different from that to which the receiver is connected.
- Consult the dealer or an experienced radio/TV technician for help.

**Modifications:** Any modifications made to this device that are not approved by RCF may void the authority granted to the user by the FCC to operate this equipment.

## 2. DESCRIPTION

### TOUR SOUND

HD 10-A Mk5 and HD 12-A Mk5 represent the latest evolution in the active loudspeaker technology with a revolutionary design and sound. Every detail has been carefully studied in order to offer musicians and professionals the perfect tool to amplify their performance, night after night. High quality materials, precise manufacturing, careful assembly and extensive quality control procedures complete the groundbreaking design work of the RCF R&D team. The vocals are natural, the sound is clear at longer distances, the spl power is stable at very high levels.

### LEGENDARY TRANSDUCERS

The high power transducers equipping HD 10-A Mk5 and HD 12-A Mk5 have been representing for decades the ultimate performance, the highest power handling and the most advanced technology in the professional and touring industry.

All Compression drivers and Transducers are precision built taking advantage of RCF's superior moulding, assembly technologies and a wealth of professional knowledge and experience dedicated to achieving extremely high standards. The high power woofer delivers extremely accurate punchy bass, the custom made compression driver offers a transparent midrange and extreme fidelity.

### DIGITAL PROCESSING FOR DIGITAL POWER

RCF Class-D power amplifiers technology packs huge performance operating with high efficiency into a lightweight solution. HD 10-A Mk5 and HD 12-A Mk5 amplifiers deliver ultra fast attack, realistic transient response and impressive audio performance.

The integrated DSP manages crossover, equalisation, soft limiter, compressor and dynamic bass boost.

Each input board presents both XLR/jack balanced inputs, XLR output link, mic/line switch, volume and a switchable EQ Mode (Flat/Boost).

The amplifier features a solid mechanical aluminum structure which not only stabilize the amplifier during transportation but also assist in the heat dissipation. All the HD 10-A Mk5 and HD 12-A Mk5 amplifiers presents SMPS power supply section in order to produce maximum output and minimum transportation weight.

### RENTAL PROOF

HD 10-A Mk5 and HD 12-A Mk5 cabinets are moulded on a special polypropylene composite material designed to dampen down vibrations even at maximum volume settings. From moulding to the final texture, HD 10-A Mk5 and HD 12-A Mk5 offers the maximum reliability and strength for the intensive use on the road. The reflex porting has been resized to offer a better efficiency.

The HD 10-A MK5 is equipped with a top handle and a side handle with rubber handgrip for greater portability; the HD 12-A Mk5 features 3 ergonomically designed forged handles with rubber handgrip, 2 on the sides and one at the top. At the bottom a rugged steel pole mount has been installed in all models. The new cabinet shape will allow HD 10-A Mk5 and HD 12-A Mk5 models to be used in the standard configuration as well as in stage monitor model. Two M10 threaded inserts are provided for optional mounting hardware in Installed Sound Applications.

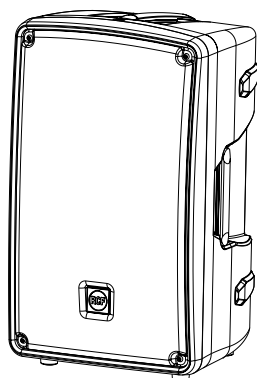

#### HD 10-A MK5

800 Watt  
10" Woofer - 2" v.c.  
1" Compression Driver  
12,1 Kg (26.6 lbs)

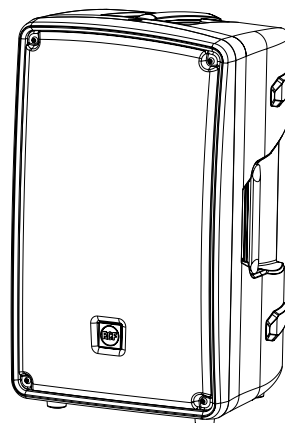

#### HD 12-A MK5

1400 Watt  
12" Woofer - 2,5" v.c.  
1.4" Compression Driver  
17.4 Kg (38.3 lbs)

- 1 **JACK/FEMALE XLR INPUTS (BAL/UNBAL)** The system accept jack or XLR input connectors. These balanced inputs can be used to connect balanced or unbalanced microphones or audio sources at line level. The balanced connector is connected in parallel and can be used to send the audio signal to other amplified speakers, recorders or supplementary amplifiers.
- 2 **LIMITER LED** The amplifier has a built in limiter circuit to prevent clipping of the amplifiers or overdriving the transducers. When the soft clipping circuit is active the LED blinks RED. It is okay if the limit LED blinks occasionally. If the LED blinks frequently or lights continuously, turn down the signal level.
- 3 **SIGNAL LED** The signal indicator lights green if there is signal present on the main input.
- 4 **POWER STATUS LED** This green led is ON when the speaker is connected to the mains power source and the ON/OFF switch is in ON position.
- 5 **MALE XLR SIGNAL OUTPUT** The output XLR connector provides a loop trough for speakers daisy chaining.
- 6 **VOLUME CONTROL** Adjust the amplifier volume. This control does not affect the "Link" - "Input - Link" output level.
- 7 **FLAT/BOOST SWITCH** Set the flat or boost equalization. "Boost" equalization is a loudness recommended for background music applications, when the system plays at a low level. For all other applications "Flat" equalisation is recommended.
- 8 **INPUT SENSITIVITY SWITCH** Position the switch in LINE to use a line level source (0 dB) or MIC to use a microphone source.
- 9 **IEC AC SOCKET** The IEC AC socket connect the power cord to the socket.
- 10 **FUSE CARRIER** Mains fuse housing.
- 11 **POWER MAINS SWITCH** The power switch turns the AC power ON and OFF.

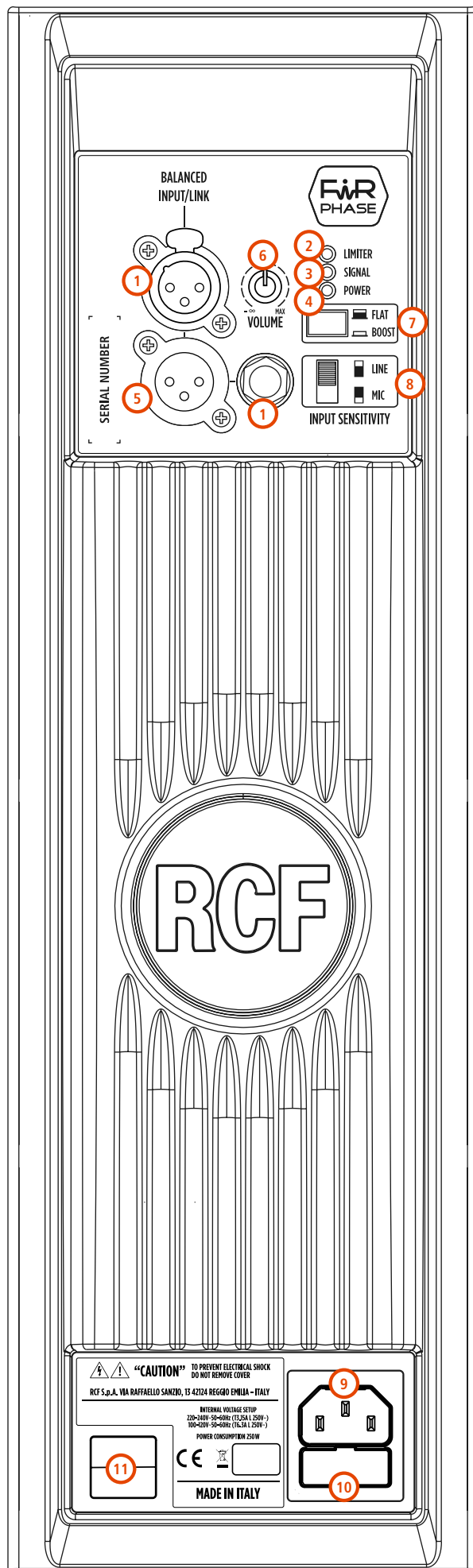

**⚠ ⚠ WARNING! CAUTION! Loudspeaker connections should be only made by qualified and experienced personnel having the technical know-how or enough specific instructions (to ensure that connections are made correctly) in order to prevent any electrical danger.**

**To prevent any risk of electric shock, do not connect loudspeakers when the amplifier is switched on.**

**Before turning the system on, check all connections and make sure there are no accidental short circuits.**

**The entire sound system shall be designed and installed in compliance with the current local laws and regulations regarding electrical systems.**

## 4. CONNECTIONS

The connectors must be wired according to the standards specified by the AES (Audio Engineering Society).

**MALE XLR CONNECTOR**  
Balanced wiring

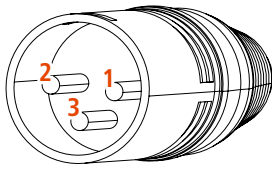

**FEMALE XLR CONNECTOR**  
Balanced wiring

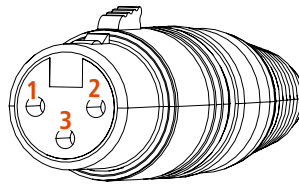

**PIN 1** = GROUND (SHIELD)  
**PIN 2** = HOT (+)  
**PIN 3** = COLD (-)

**TS JACK CONNECTOR**  
Unbalanced mono wiring

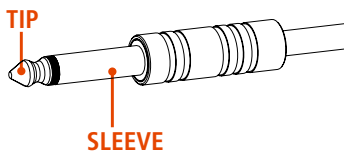

**TRS JACK CONNECTOR**  
Balanced mono wiring

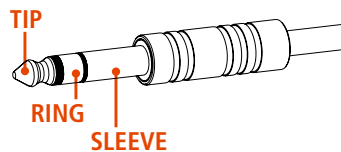

**SLEEVE** = GROUND (SHIELD)  
**TIP** = HOT (+)  
**RING** = COLD (-)

### BEFORE CONNECTING THE SPEAKER

On the rear panel you will find all the controls, signal and power inputs. At first verify the voltage label applied to the rear panel (115 Volt or 230 Volt). The label indicates the right voltage. If you read a wrong voltage on the label or if you can't find the label at all, please call your vendor or authorized RCF SERVICE CENTRE before connecting the speaker. This fast check will avoid any damage.

In case of need of changing the voltage please call your vendor or authorized RCF SERVICE CENTRE. This operation requires the replacement of the fuse value and is reserved to an RCF SERVICE CENTRE.

### BEFORE TURNING ON THE SPEAKER

You can now connect the power supply cable and the signal cable. Before turning on the speaker make sure the volume control is at the minimum level (even on the mixer output). It is important that the mixer is already ON before turning on the speaker. This will avoid damages to the speaker and noisy "bumps" due to turning on parts on the audio chain. It is a good practice to always turn on the speakers at last and turning them off immediately after their use. You can now turn ON the speaker and adjust the volume control to a proper level.

### TURNING ON THE SPEAKER

The amplifiers are equipped with a microprocessor to control the DSP and the amplifier. The correct switch on of the amplifier is ensured by an initialisation procedure; during this test stage the LEDs (Limiter, Signal and Power Status), located on the amplifier module, remain off for approx. 2 sec. At the end of the switch on procedure on the amplifier module the Ready green LED only remains steadily on. In case of severe failure of the speaker, the LED on the front panel flashes several times and on the amplifier module, the Limiter red LED flashes. The speaker switches to "mute".

---

### VOLTAGE SETUP (RESERVED TO THE RCF SERVICE CENTRE)

**200-240 Volt, 50 Hz SETUP:**  
**FUSE VALUE T 3.15 A L 250V**

**100-120 Volt, 60 Hz SETUP:**  
**FUSE VALUE T6.3 A L 250V**

---

The microprocessor is able to signal three different kinds of failure by flashing the "Limiter" red LED on the amplifier panel before the lighting up of the "Power status" green LED.

The three types of failure are:

- **WARNING:** a non severe error or auto-ripristinate malfunction is detected and the performance of the speaker is not limited.
- **LIMITATIONS:** an error is detected and the performance of the speaker is limited (the sound level is reduced by 3 dB). This does not affect the operation of the speaker since it continues to operate. However, it is necessary to call the service centre to solve the issue.
- **FAILURE:** a severe malfunction is detected. The speaker switches to "mute".

### **FLASHING INDICATION:**

1 or 2 : **Warning**

3 or 4 : **Limitation**

5 to 8 : **Failure.** In case of failure, the "Ready" green LED remains off.

Perform the checks listed below:

- check if the speaker is properly connected to the power supply
- make sure that the power supply is of correct voltage
- check that the amplifier is not overheated
- disconnect the speaker from the mains power supply, wait for a few minutes and connect it again. If after these tests the red "LIMITER" LED is still on, please contact an authorised service centre.

## 6. INSTALLATION

### FLOOR CONFIGURATIONS

Several configurations are possible with HD 10-A MK5 and HD 12-A MK5 Speakers; they can be placed on the floor or on a stage as main PA or used as stage monitors; they can also be pole mounted on a speaker stand or over a subwoofer.

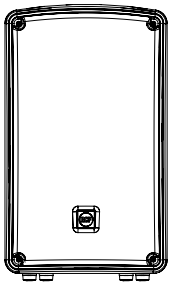

**FLOOR OR STAGE  
STANDING**

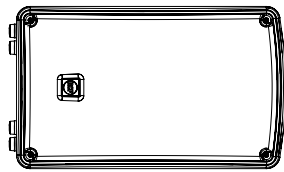

**STAGE  
MONITOR**

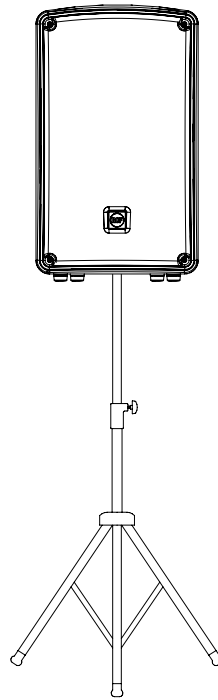

**POLE  
MOUNTED**

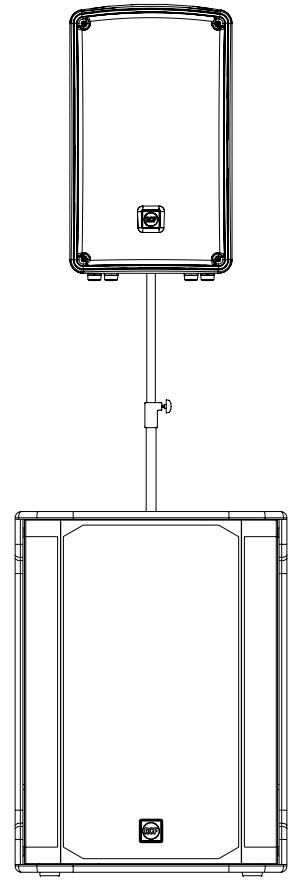

**SUBWOOFER  
MOUNTED**

### SUSPENDED CONFIGURATIONS

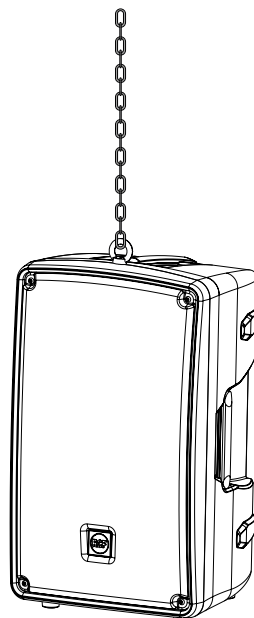

HD 10-A MK5 and HD 12-A MK5 can be suspended from the M10 suspension points located on the top and on the bottom of the speakers.



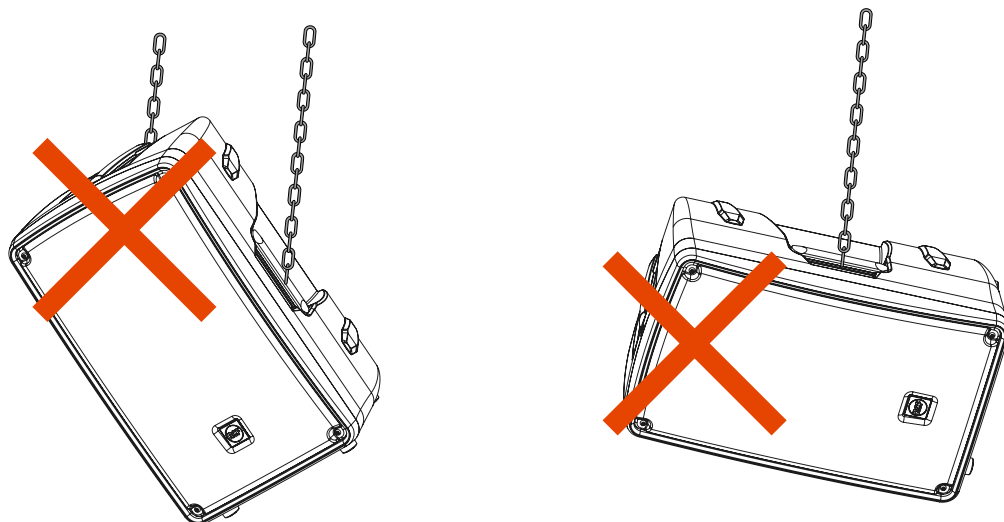

**Example of proper hanging**





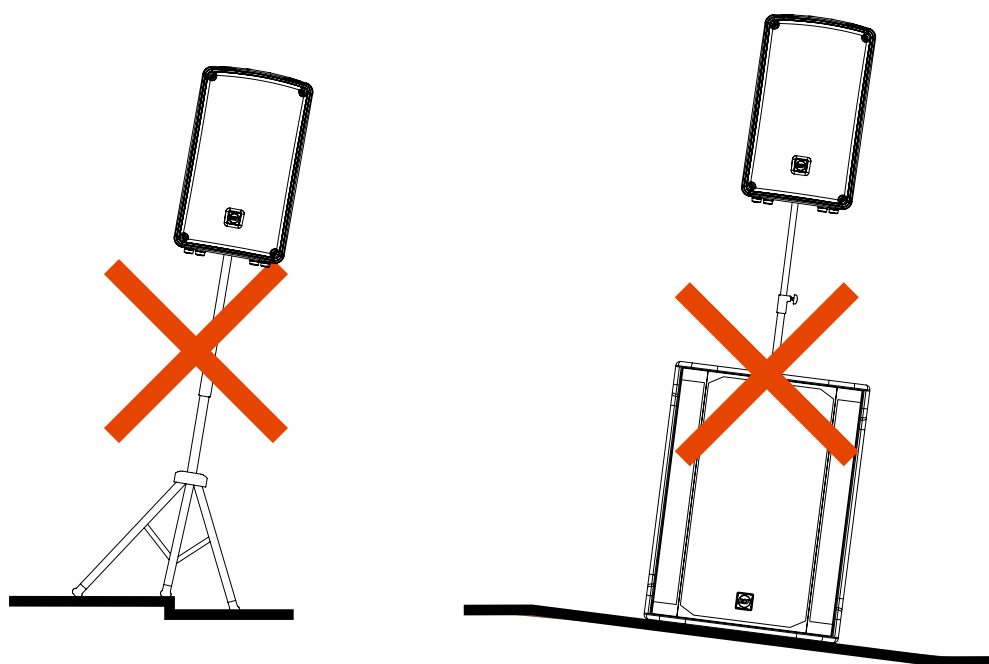

  **WARNING! CAUTION!** Never suspend the speakers by their handles. Handles are intended for transportation, not for rigging.



  **WARNING! CAUTION!** To use this product on a pole stand or over a subwoofer, before installing the system, please verify the allowed configurations and the indications regarding the accessories, on the RCF website to avoid any danger and damages to people, animals and objects. In any case, please assure the pole stand or the subwoofer which are holding the speaker are located on an horizontal floor and without inclinations.

  **WARNING! CAUTION!** The use of these speakers with Stand and Pole Mount accessories can be done by qualified and experienced personnel only, trained appropriately on professional systems installations. In any case it's the user's final responsibility to ensure the system safety conditions and avoid any danger or damage to people, animals and objects.

### **THE SPEAKER DOESN'T TURN ON**

Make sure the speaker is switched on and connected to an active AC power

### **THE SPEAKER IS CONNECTED TO AN ACTIVE AC POWER BUT DOESN'T TURN ON**

Make sure the power cable is intact and connected correctly.

### **THE SPEAKER IS ON BUT DOESN'T MAKE ANY SOUND**

Check if the signal source is sending correctly and if the signal cables are not damaged.

### **THE SOUND IS DISTORTED AND THE OVERLOAD LED BLINKS FREQUENTLY**

Turn down the output level of the mixer.

### **THE SOUND IS VERY LOW AND HISSING**

The source gain or the output level of the mixer might be too low.

### **THE SOUND IS HISSING EVEN AT PROPER GAIN AND VOLUME**

The source might send a low quality or noisy signal

### **HUMMING OR BUZZING NOISE**

Check out the AC grounding and all the equipments connected to the mixer input including cables and connectors.



**WARNING!** to reduce the risk of electric shock, do not disassemble this product unless you are qualified.  
Refer servicing to qualified service personnel.

---

# HD 10-A MK5 DIMENSIONS

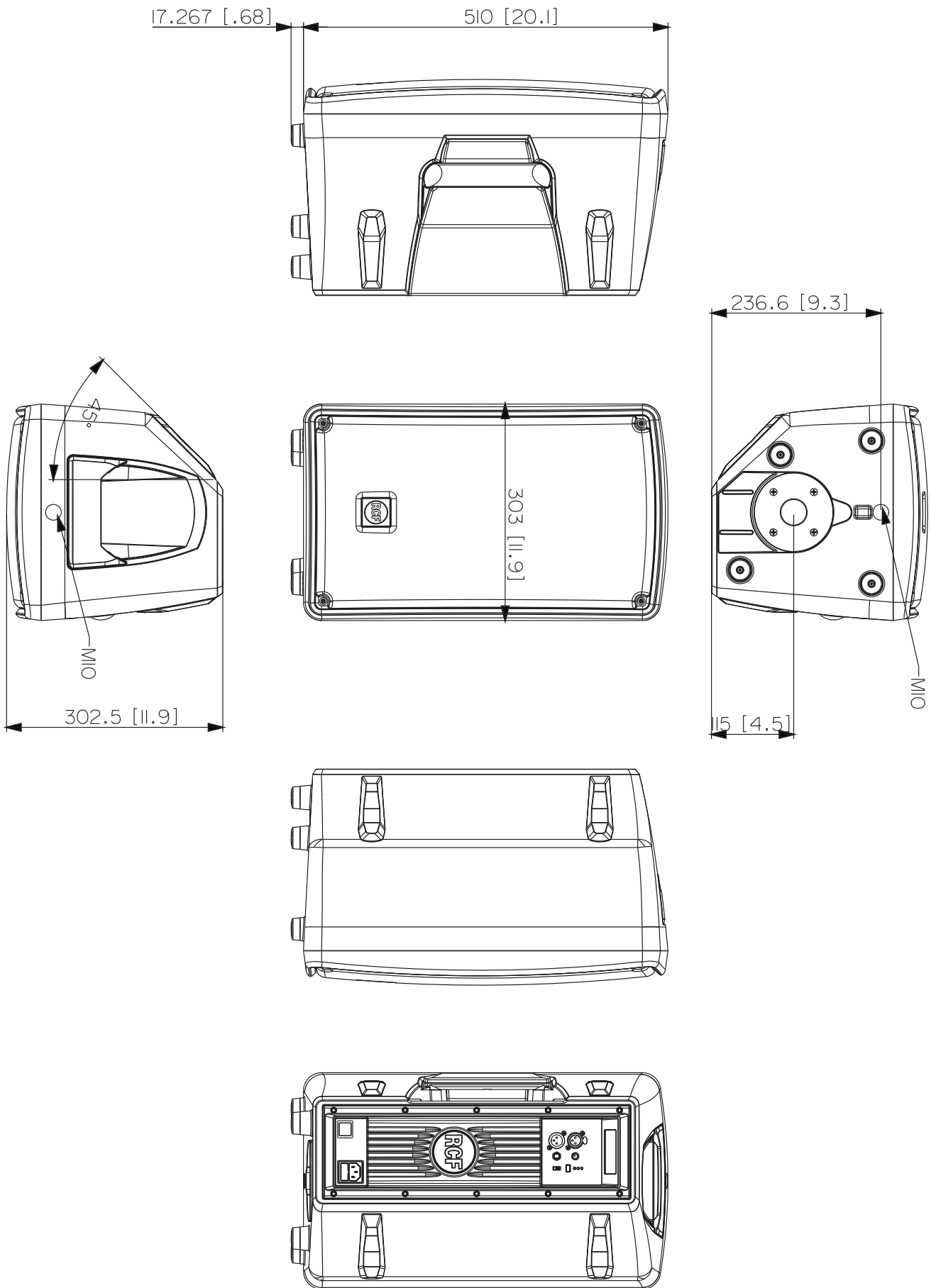

# HD 12-A MK5 DIMENSIONS

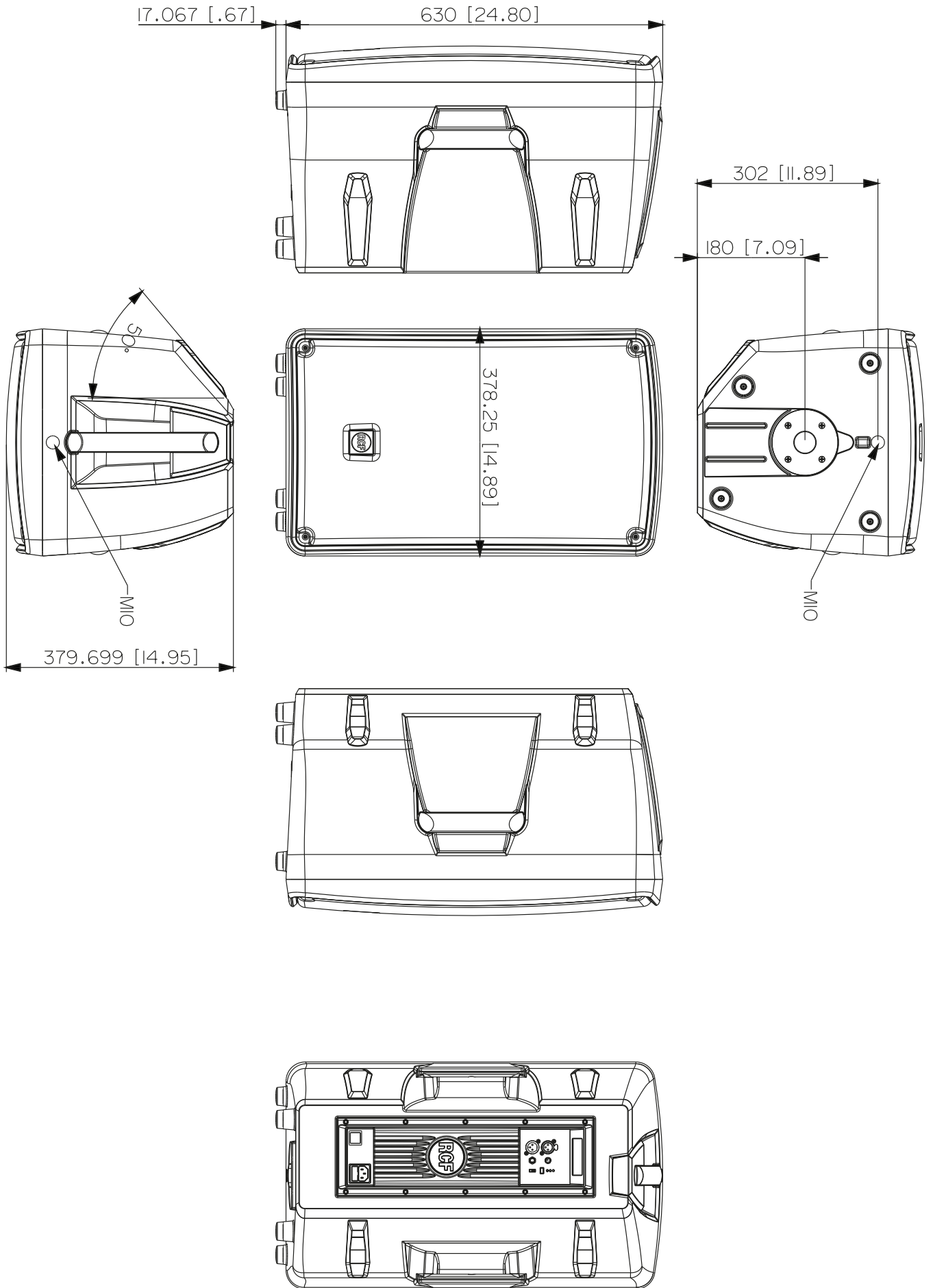

## SPECIFICATION / SPECIFICHE

TECHNICAL SPECIFICATIONS		HD 10-A MK5	HD 12-A MK5
<b>Acoustical specifications</b>	Frequency Response:	50 Hz ÷ 20000 Hz	45 Hz ÷ 20000 Hz
	Max SPL @ 1m:	128 dB	130 dB
	Horizontal coverage angle:	90°	90°
	Vertical coverage angle:	60°	60°
<b>Transducers</b>	Compression Driver:	1.0", 1" v.c	1.0", 1.4" v.c
	Woofer:	10", 2.0" v.c	12", 2.5" v.c
<b>Input/Output section</b>	Input signal:	bal/unbal	bal/unbal
	Input connectors:	XRL, Jack	XRL, Jack
	Output connectors:	XLR	XLR
	Input sensitivity:	-2 dBu/+4 dBu	-2 dBu/+4 dBu
	Mic. Input Sensitivity:	-32 dBu	-32 dBu
<b>Processor section</b>	Crossover Frequencies:	2000 Hz	1800 Hz
	Protections:	Thermal, RMS	Thermal, RMS
	Limiter:	Soft Limiter	Soft Limiter
	Controls:	Boost, Volume, Mic/Line	Volume, Boost, Mic/Line
<b>Power section</b>	Total Power:	800 W Peak, 400 W RMS	1400 W Peak, 700 W RMS
	High frequencies:	200 W Peak, 100 W RMS	400 W Peak, 200 W RMS
	Low frequencies:	600 W Peak, 300 W RMS	1000 W Peak, 500 W RMS
	Cooling:	Convection	Convection
	Connections:	VDE	VDE
<b>Standard compliance</b>	CE marking:	Yes	Yes
<b>Physical specifications</b>	Cabinet/Case Material:	PP Composite	PP Composite
	Hardware:	1 x M10 top, 1 x M10 bottom, 3 x M6 bottom	1 x M10 top, 1 x M10 bottom, 3 x M6 bottom
	Handles:	1 Top, 1 Side	1 Top, 2 Side
	Pole mount/Cap:	Yes	Yes
	Grille:	Steel	Steel
	Color:	Black	Black
<b>Size</b>	Height:	527 mm / 20.75 inches	647 mm / 25.47 inches
	Width:	303 mm / 11.93 inches	380 mm / 14.96 inches
	Depth:	303 mm / 11.93 inches	380 mm / 14.96 inches
	Weight:	12,1 kg / 26.6 lbs	17,4 kg / 38.3 lbs
<b>Shipping informations</b>	Package Height:	640 mm / 25.2 inches	760 mm / 29.92 inches
	Package Width:	400 mm / 15.75 inches	500 mm / 19.69 inches
	Package Depth:	380 mm / 14.96 inches	500 mm / 19.69 inches
	Package Weight:	14 kg / 30.86 lbs	21.4 kg / 47.18 lbs

